

Box with brass threaded inserts

Emiliano Achaval uses brass threaded rings to make this olive root burl box

You might wonder why I am writing an article about boxes that don't involve the traditional hand-chased threads. The main reason is that I get many requests for boxes made with the beautiful native Hawaiian hardwoods we are lucky to have in the islands. Very few are dense enough to take threads.

I have made a lot of Acacia Koa boxes with boxwood and other dense timbers as threaded inserts, but they take a lot more time to create than the ones using the brass threaded rings I will show you. Another important reason is that they are a lot of fun to make. This project can be done by everyone, even someone who is just getting started. You need a few essential tools, the brass inserts, and the correct epoxy.

I had a student who went home from his second day of classes with a great-looking box. The only reason he didn't finish it on the first day was that the epoxy took 24 hours to cure. We now have two companies manufacturing nice and stylish brass inserts. They come in different sizes, so you are bound to find the right one for your project.

I started using brass inserts for the urns I make. I only considered using them for smaller containers when a collector asked me for a koa keepsake urn. The possibilities are endless. Once you buy the box, it is yours to do with whatever you please. So far, some intended uses have been ring boxes, pet urns, keepsake urns, pill boxes, natural medicine keepers, and lots more.

On the design side, only your imagination is the limit. You could also embellish, carve, burn, or paint it. I had some failures with some of the epoxies I experimented with. Wood will move, heat and cold, and humidity will cause it to expand and shrink. I will share what epoxy I have been using with good results. As with any other box, you want your wood to be dry and stable to minimise movement.

The holy grail of box-making is grain alignment. The brass inserts make it easy to get a perfect grain match every time.

For this project, I chose a blank of olive root burl, which is a fairly dense wood. Let's go to the shop and get started. I can guarantee you this is going to be fun.



PHOTOGRAPHS BY EMILIANO ACHAVAL



Plans & equipment

Tools & materials

- PPE & RPE as appropriate
- Olive root burl blank, or timber of your choice, in this case 5in long x 2.5in wide
- Scrap of red oak, or timber of your choice
- Spindle roughing gouge
- Bowl gouge
- Negative rake scraper
- Point tool
- Beading tool
- Sanding up to 320 or 400 grit
- Brass threaded inserts
- Epoxy (with 'flex')
- Small container to measure and mix epoxy
- Kitchen skewer to mix and spread epoxy
- Small scale
- Shop towels

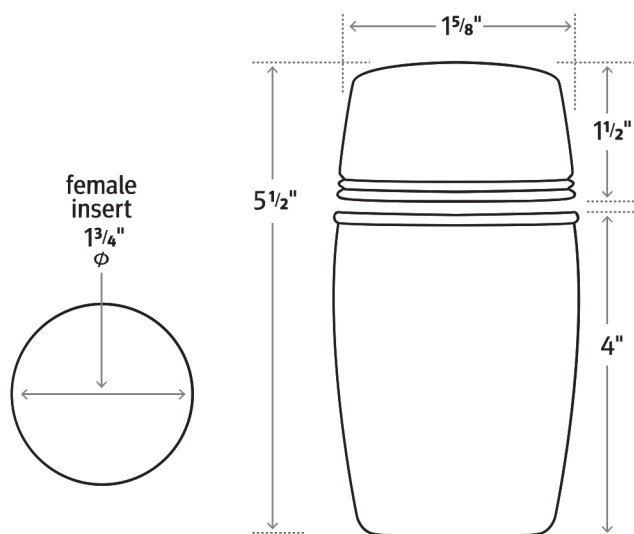

The Golden Ratio

The Golden Ratio, or Golden Mean, is a ratio of approximately 1.618. Here's a diagram but you can find plenty of resources online about the Golden Ratio, and the Fibonacci Sequence, from which it's derived, where each number is the sum of the two preceding ones (5, 8, 13, 21, 34, etc.) By using the Golden Mean when designing your projects, you can achieve more appealing proportions. If you search online, you can even find plans for making a set of Golden Mean gauges to assist you in this.

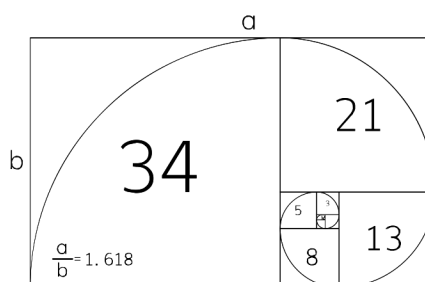

The making

1 We will start with a blank of about 5in long x 2.5in wide. This is an end-grain project. Mark the centres and mount the blank on the lathe. Using a spindle roughing gouge, bring the blank to a round. Alternatively, if you do not have a spindle roughing gouge, you could use a bowl gouge for this step.

2 With a skew, turn a tenon on each side. I recommend using a small chuck for box-making – it gives more access to the bottom than a larger chuck. I'm using a Vicmarc VM100 with the standard jaws. With a spare chuck jaw, measure for a good fit – you do not want any wobbliness once it goes on the chuck.

3 Gently clean up any tool marks with a negative rake scraper. I have mine with 25° on each side. On dense woods, you could finish shaping the form a little. Be careful on softer woods; if you lose the burr, you could tear up the grain.

4 You always want to stay close to the Golden Ratio (see above) when making boxes. Considering the tenons and the overall design, measure approximately a third of the way. That will become the lid.

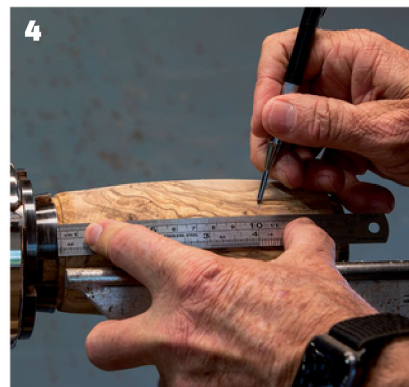

5 You will now separate the lid. Thin parting tools, especially the ones with a short handles, are some of the most dangerous. They can bind without warning. I recommend a long-handled parting tool.

6 Go about a third of the way and finish cutting with a hand saw, with the lathe switched off. You can't see it in the picture, but I have a small piece of cardboard on the bedway. This is to prevent the saw from hitting it. You can see that I forgot once to have the protection, and I lost some teeth on the saw.

7 You are going to start with the bottom part of the box. Leave it in the chuck. Clean up the area you just cut with a small bowl or spindle gouge. Be careful – this is an end-grain project. Ensure you lock in the tool with your thumb on the toolrest to prevent the kickback. If you are uncomfortable with an end-grain cut, you can always use a negative rake scraper, scraping gently towards the headstock.

8 You are now ready to measure where the brass insert goes with callipers and transfer it to the top of the box. Be careful; only touch the wood with the left side of the callipers (read the panel below about choosing the male or female insert). Measure the centre of the insert.

TOP TIP

Male or female?

I was asked why I chose to have the female insert on the bottom. I'm all about design. I don't like the male spigot not being flush with the box. The female has a cleaner look. I would use the male on the bottom if the intended use would be an urn; ashes could potentially end up on the threads. It is ultimately up to you, the maker, to choose what you want.

9A/B Patience here will pay off. With a parting tool, take a few plunging cuts. Test the fit often. You do not want a tight fit, you need to have some play to allow for the resin to get in and work. You should be able to move the insert back and forth slightly. You also want it flush.

10A/B Drill to depth with a drill, or Forstner bit. Some purists might say that using a Forstner bit is cheating – I like to use any tools that make the job easier. Do not choose too large a bit. You want to have some room left to give it a nice finish. Measure the depth before cleaning up the Forstner tool marks.

11 The Forstner bit will leave a rough surface, especially on the bottom. My go-to tool for this clean-up is a Badger No.5 from Hunter Tools. With some practice, you can leave a glossy surface on the bottom.

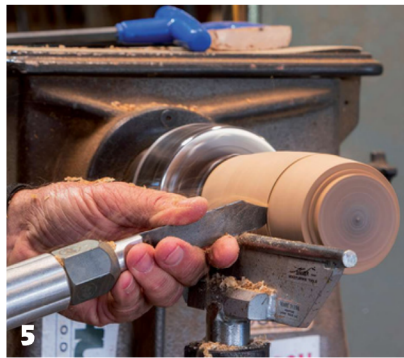

12 Nobody likes sanding, we can all agree on that. To leave an almost perfect surface, I have a small but thick negative rake scraper with a round nose and a profile that comes down nearly 2in on the left side. My angles are 40° on the top and 25° on the bottom. Another good choice would be to use a traditional scraper.



13 You are now ready to sand the inside. Wrap some sandpaper on a dowel or whatever you have lying around. The idea is not to do it just by holding the paper with your fingers. I lost my surgical lockable scissors in the shavings. As soon as I remember to order a new one, that's what I will be using.



14 Before you take the box off the chuck, you need to make some grooves in the insert recess. These grooves will help increase your success rate with the epoxy you will use. I use my recess tool, which is the tool we use when chasing threads to make a recess or an 'escape hatch', as I call it. You could also use a point tool or make one with a small Allen wrench.



15 Set aside the bottom part, put the lid back on the chuck and make sure it runs true. I usually mark jaw number one to put it back exactly where it was, increasing the chances of zero wobble. Clean the saw marks with a small bowl gouge, spindle gouge, or an NRS, pushing towards the headstock.



16 The process for the lid is similar to the bottom. Start by measuring the female insert – I prefer to measure the centre. Transfer that to the lid, making sure not to touch the right side of the callipers.

17 With a parting tool, start cutting the recess. Remember, you do not want a tight fit. You need room for the epoxy to get in and do its magic.

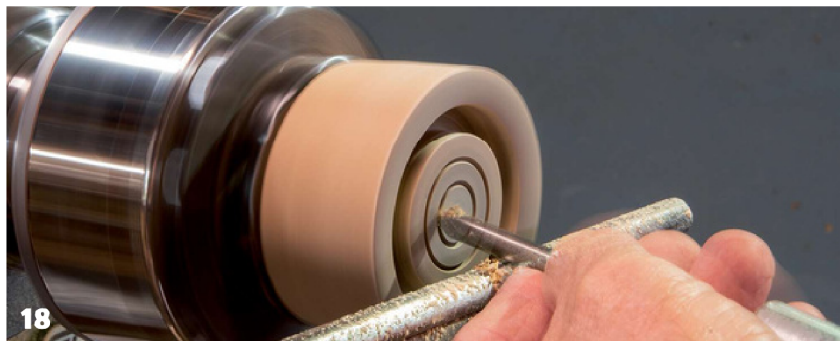

18 I like adding some decorations, the same as we will do on the bottom, inside of the lid. Use your favourite texturing, chattering, or point tool. People like to open the box, and find a little surprise there.

19 After experimenting with several epoxies, with lots of mixed results (pun intended), I have settled for the one that has given me zero failures for several years. (See below right.) Gather all the supplies needed and put a paper towel inside the box to catch any excess epoxy.



TOP TIP

Epoxy

Because we work with a medium that will shrink and expand, we have to compensate for that movement. After a few failures with the epoxies I was using, I decided to do some research. I set up an appointment with someone at our local fibreglass and epoxy store. He suggested I try the G/Flex from West Systems. The main characteristic of this epoxy is that it will 'flex' with the wood, unlike most other epoxies that are very hard and will crack or even separate from the wood. The knurled surface on the inserts helps with the adhesion. Whatever brand you find, make sure that it will allow for movement.



20



21

20 Because we are looking for a good grain match, we will carefully measure to see where you will glue them. Screw both inserts together and drop them in the female recess. With a permanent marker, mark on the brass where a distinctive feature in the grain is easily recognisable. I chose a crack that runs almost all the way down.

Measuring the equal parts of the epoxy by weight is more accurate. I use a kitchen skewer to spread the epoxy evenly on the recess and some on the knurled portion of the insert. A small, inexpensive brush also works well. Do not overload the recess; you do not want epoxy oozing on to the threads.

21 Drop in the insert and twist around to spread the epoxy evenly. Line up the mark with the grain feature you chose. Wipe any excess off. Let the epoxy dry for 24 hours. You can see that I marked more than one area, which makes it easier to ensure alignment. Once the female insert is dry, screw in the male insert, put the lid on and match the grain. Carefully lift and mark where the last insert goes. Repeat the epoxy job. Let it dry.

22 You patiently waited for the epoxy to dry; now is the time to put the box back on the chuck and finish it. The lid might not be perfectly even with the bottom. With a spindle roughing gouge or the tool of your choice, make the box run true again.

23 Move the toolrest and finish the top of the box. A spindle gouge or small bowl gouge works fine here. The design possibilities are endless. Use your imagination and make the box your own with a unique small, finial-like decoration or just some beads encasing some chatter work.

24 Sand the lid and most of the bottom. Right before 320 grit, I like to add an odd number of beads to disguise the joint line of the box. If you do not have a beading tool, you could also use a point tool.

25 You now have to finish the bottom. A bonus with inserts is that if you keep a spare, you can use it as a reverse-threaded chuck. You can use a jam chuck if you don't have one. I prefer the extra security of a threaded one; plus, you can take the tailstock off at the last minute to finish the nub without worrying about a catch. A threaded chuck is usually more secure than a jam chuck.



26A/B Start cleaning up the small tenon with a small bowl gouge or a spindle gouge. Keep the tailstock as long as possible – it will give you extra security since the cuts initially put slight pressure sideways, and you could knock it off in the event of a catch. I like to undercut the bottom to give the form an illusion of floating above the surface (picture B). Design-wise, you do not want it sitting flat. Also, ensure you have a slightly concave surface so it sits right.

27 Remove the tailstock. Now you have access to the whole bottom. If you are uncomfortable making the last few cuts without support, you can always cut the nub off with a small saw and sand. Slice cuts towards the headstock are the safest here. You are not putting on any lateral pressure; all forces are securely directed to the chuck.

28 Make a few light passes with a negative rake scraper to clean any tool marks. If you don't have one any tool that can shear scrape, such as a regular scraper tilted at 45° or an Ellsworth-style bowl gouge, you could shear scrape with the long wing, with the handle pointing towards the floor. Sand to 320 or 400. Before taking it off the chuck, add the same decorations to match the inside. Apply the finish of your choice.



Congratulations, you are done! Don't forget to email a photo to the magazine on WTEditorial@thegmcgroup.com and tag me on Instagram and Facebook when you've made your box. Aloha from sunny Maui, Hawaii. ●

